

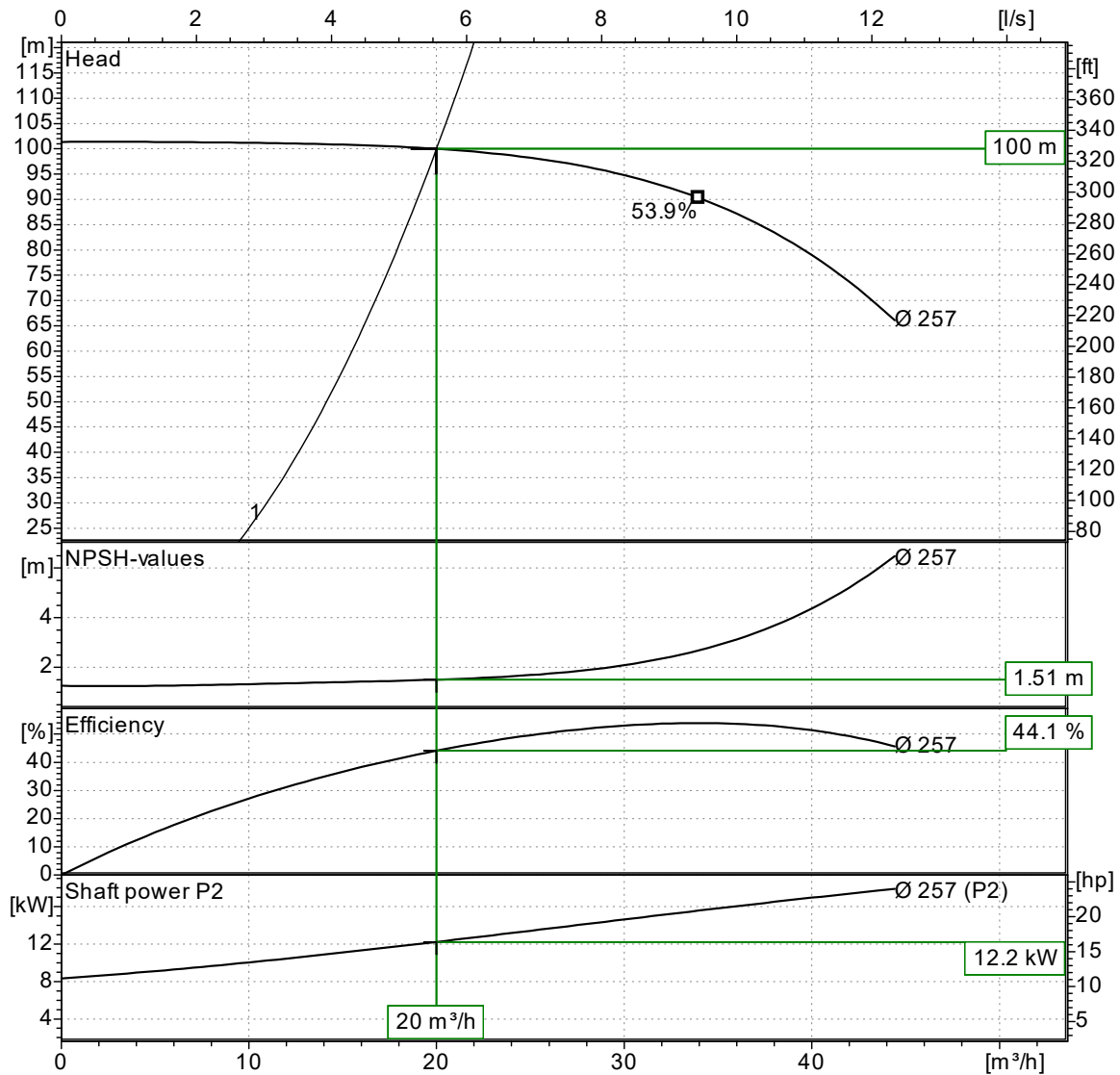

Single stage, radially split, volute casing type conforming to EN 733 and EU 547/2012

Capacity: 20.0 m<sup>3</sup>/h  
Head: 100.0 m  
Efficiency (%): 44.1  
Power at Duty Point: 12.2 kW  
Viscosity: 1.005 mm<sup>2</sup>/s

NPSHr: 1.5 m  
Motor Power: 18.50 kW  
Nominal Speed: 2930 rpm  
Frequency: 50 Hz  
Density: 998.30 kg/m<sup>3</sup>



Curves compatible with ISO 9906:2012 Gr 3B  
NPSHa > NPSHr + 1m  
Note : The motor power is not sufficient for dotted area.

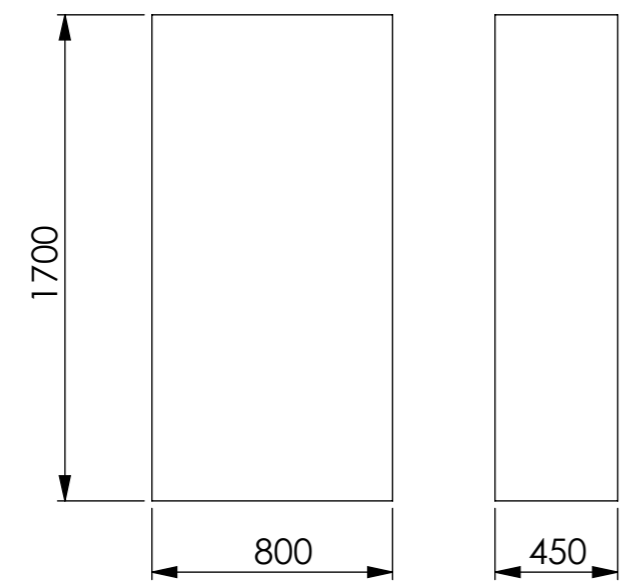
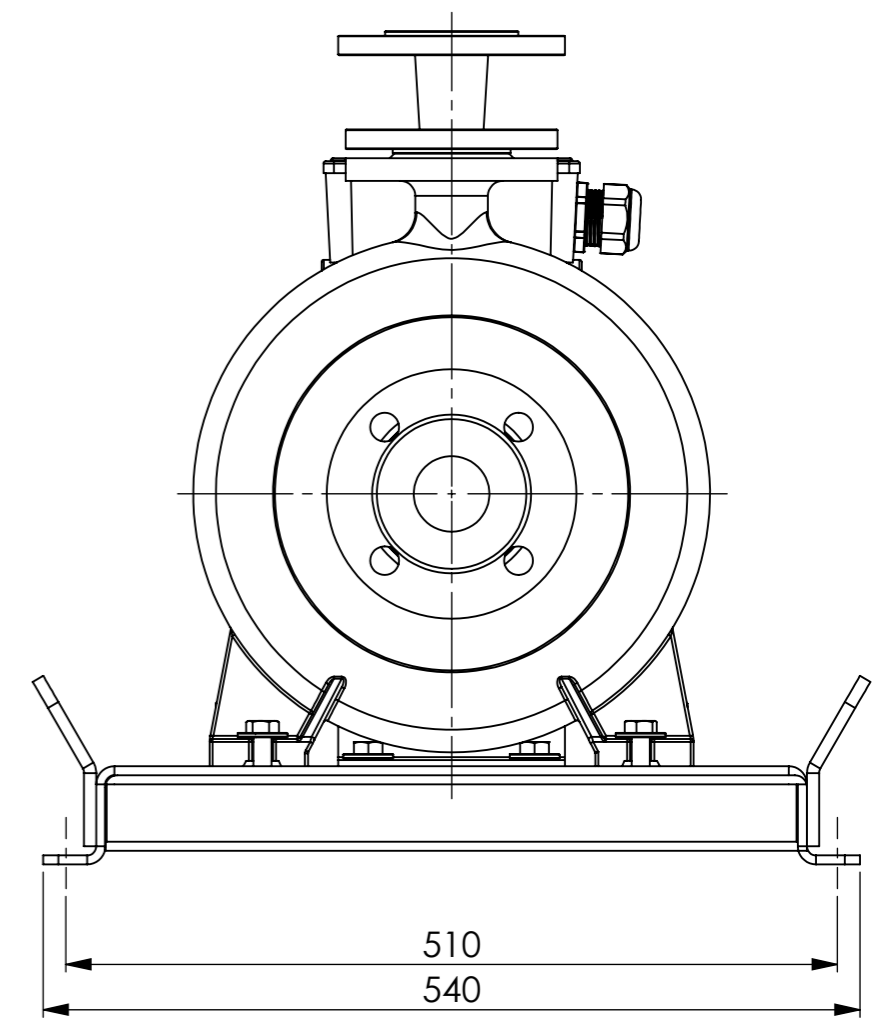
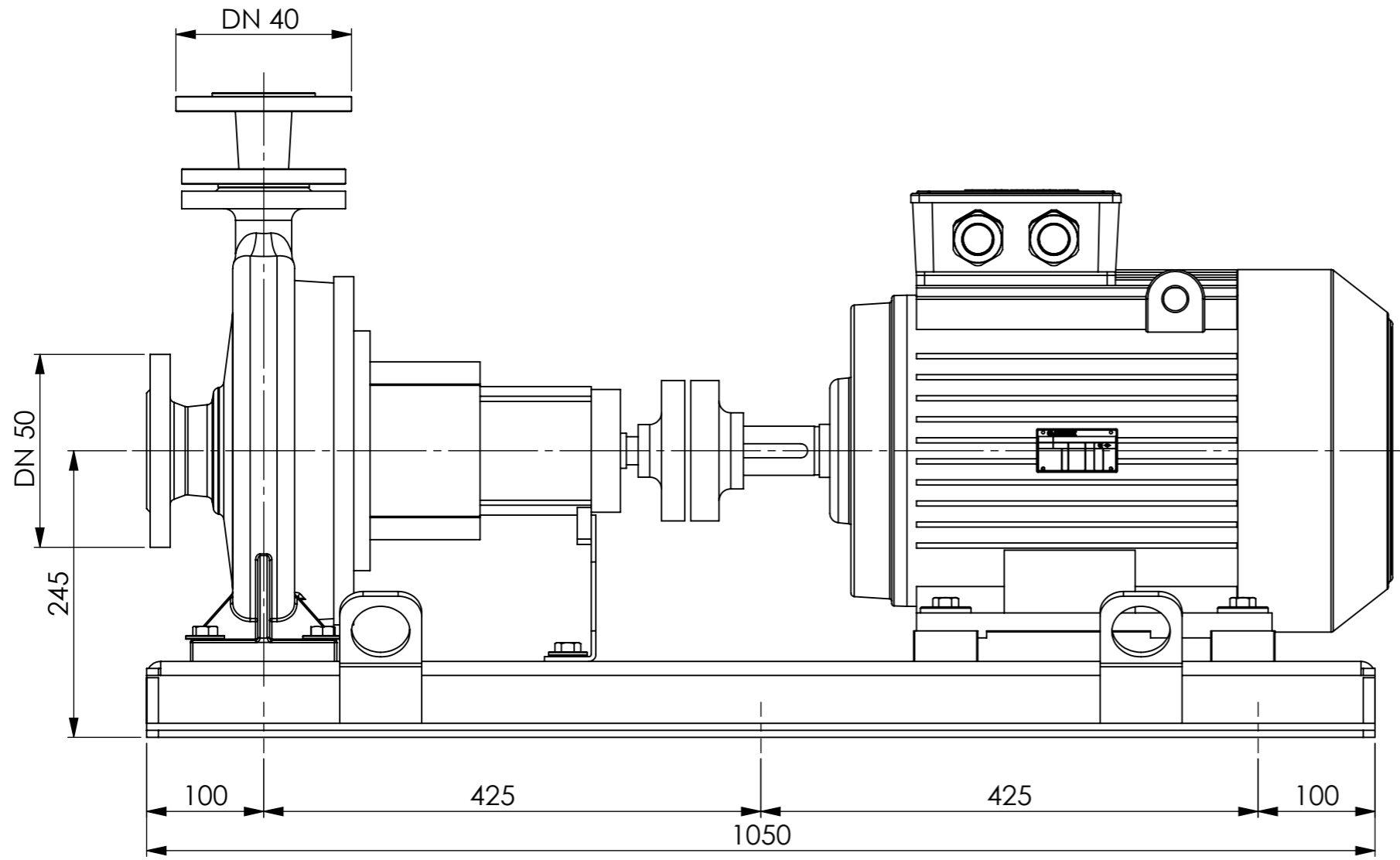

C TYPE DIESEL CONTROL PANEL